

CODE	SN109-0005-00
DATE	2009.08.14

SPECIFICATION

MODEL : HYD. CRAWLER DRILL
(JD-800)

CUSTOMER :



1. Outline

JUNJINCSM hydraulic crawler drill is a drilling machine for blasting with dynamite in the quarries, and mining and construction site. It is mainly composed of Travelling device as a base machine, Drifter, Guide shell, loading device as drilling device, power unit and running device operated by diesel engine. Differently from pneumatic drill, Air compressor and dust collector installed on the power unit make a high efficient rock drilling with low noise as much as possible.



2. Major Components

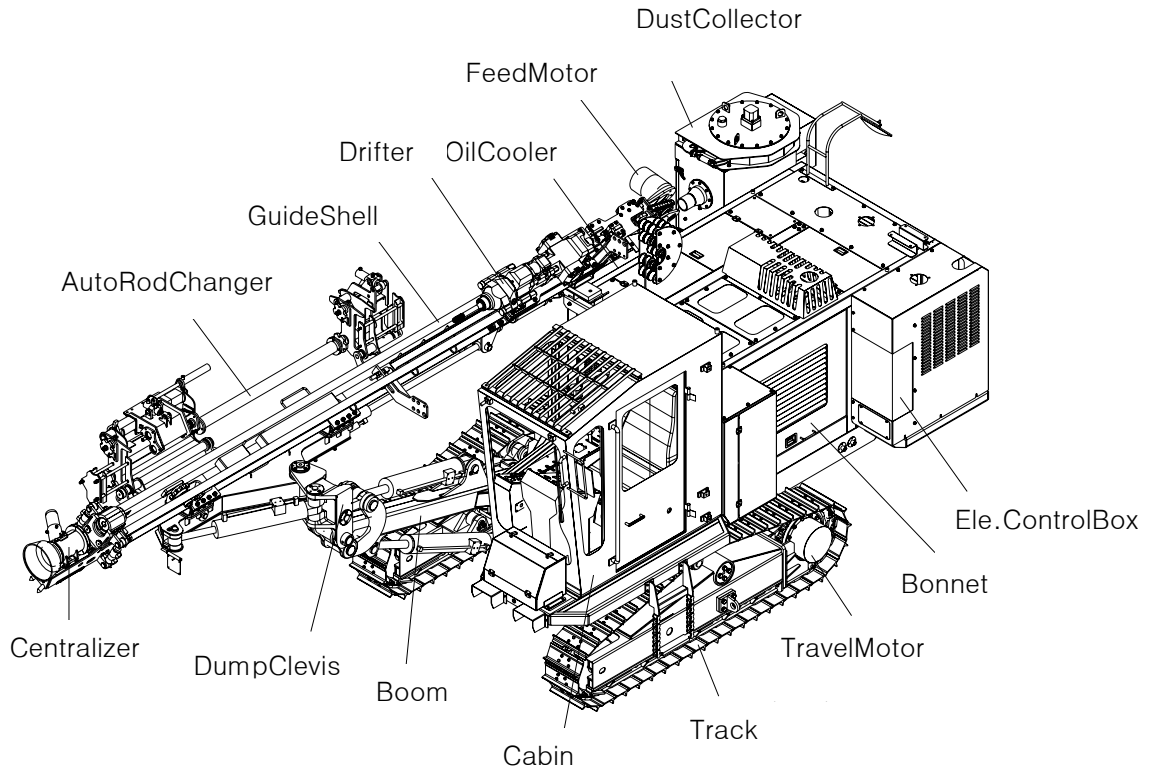

3. Coverage Range

1) Boom Up & Down With Guide Slide
(Horizontal Drill)

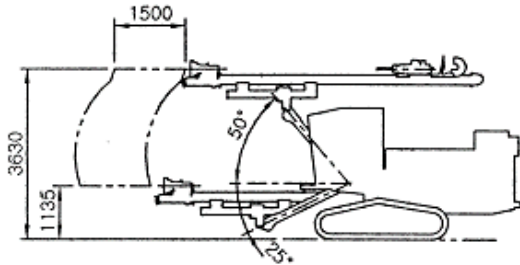

2) Boom Up & Down With Track Oscillation
(Horizontal Drill)

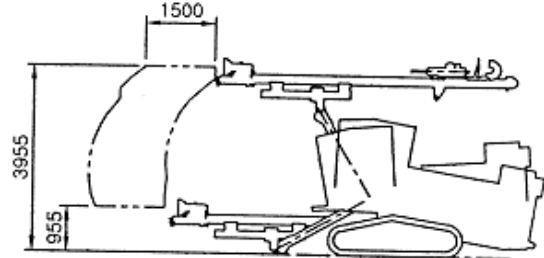

3) Boom Up & Down With Guide Slide
(Vertical Drill)

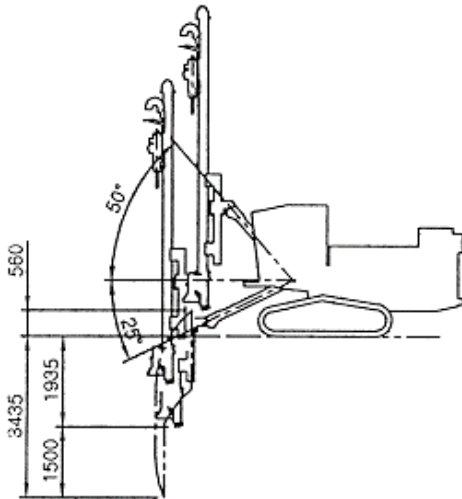

4) Boom Up & Down With Track Oscillation
(Vertical Drill)

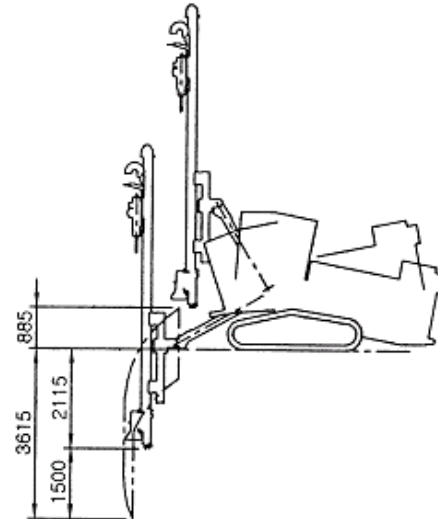

5) Boom Swing

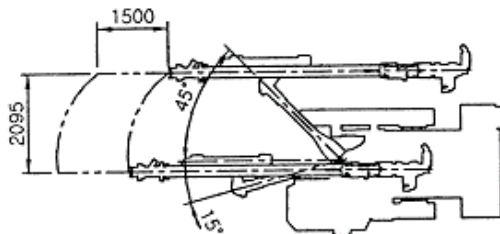

6) Track Oscillation

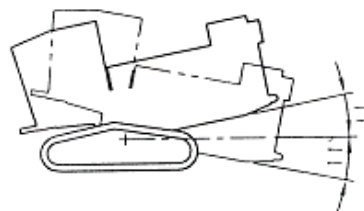

7) Guide Tilting

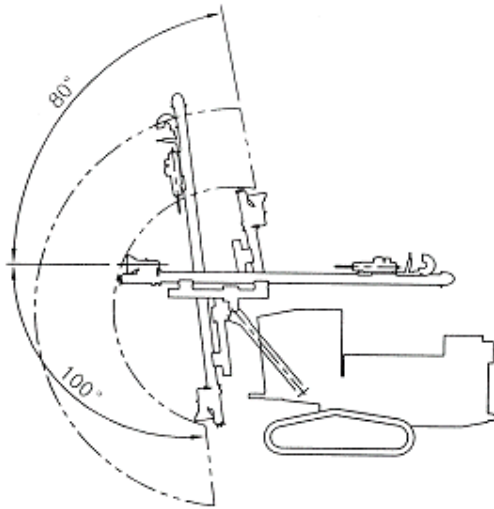

8) Guide Swing

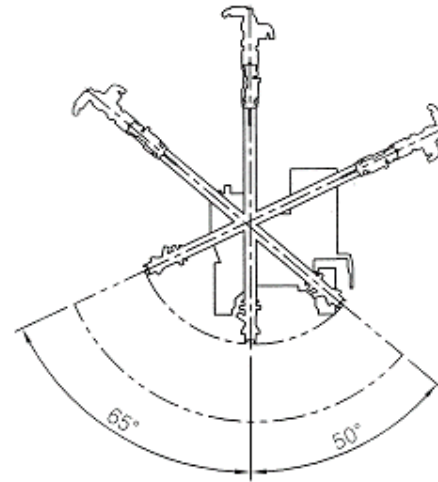

9) Horizontal Drilling Area

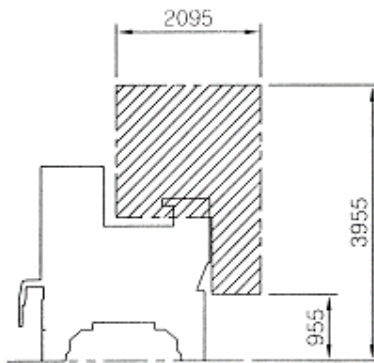

10) Vertical Drill Area

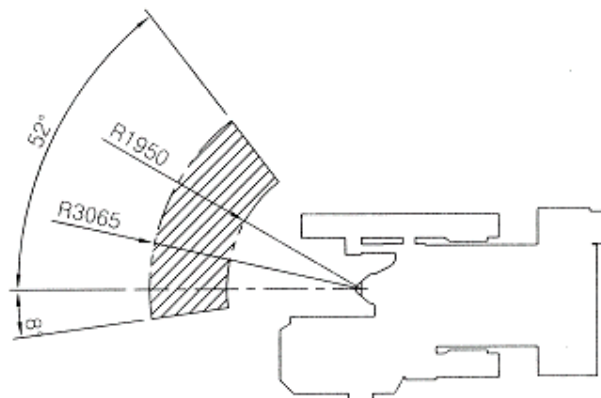

4. Features

1) Powerful Drifter JET-8

Drifter model JET-8 with hydraulic hammering system and hydraulic motor easily and speedily performs Drilling 64~102 by hammering, rotating and flushing the debris in the hole. Its simple and practical components are different from the others.

- ① Special seals adopted in the front and rear of the piston enhance its durability.
- ② Highly increased hammering energy increased drilling speed.
- ③ Chuck made of special alloy increases durability.

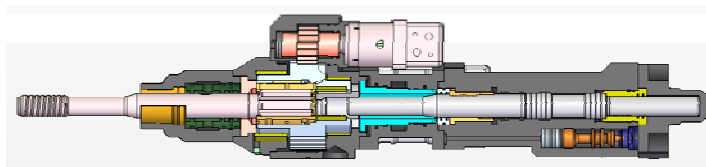

2) Innovative Power Unit

Alignment of power delivering structure decreases the engine load, which maximizes efficiency. High-performance compressor is installed to increase air outflow and radiator & cooler is installed in an independent structure to enhance stability.

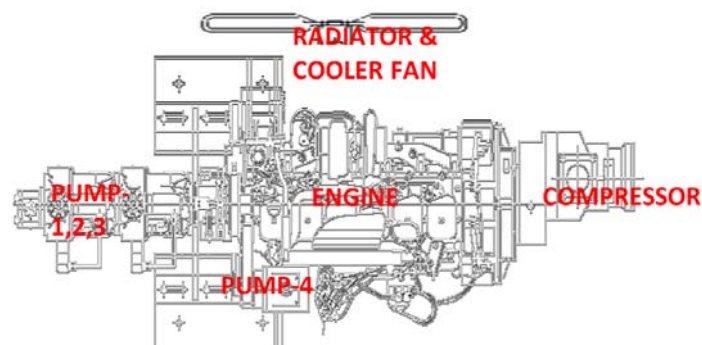

3) Working safety

- ① Tumbler length 2205mm and shoe width 340mm maximizes safety.
- ② Ground clearance 540mm and track oscillation 11on either side prevent the bottom from being damaged by projection on the rough zone.

4) Anti-jamming system

Makes the stable operation possible on all kind of rock and makes an easy operations by an unskilled operator. This will be operated only in case the anti-jamming switch is on position.

5) Collaring

Collaring makes it easy to take a correct position for drilling and an unskilled operator performs drilling correctly.

6) Travelling speed and Gradeability

The piston pump and travelling motor with high efficiency maximize its travelling speed and gradeability—Travelling speed : 3.8km/h ; Max. gradeability : 30

7) Maintenance and inspection

Panel typed bonnet and vertical typed fuel tank make more room for checking and services.

The oil drain cocks installed on either side for engine oil, gear box oil, fuel, compressor oil make the oil exchange and cleaning easy.

8) Powerful Dust Collector

- ① Dust collector with 4 filters prevents dust from flying in drilling and its filters are protected by air flushing in each filter.
- ② To prevent the filter from being damaged by a water vein, shutter installed within stop collecting dust in case a water vein appears during drilling.

9) Comfortable and safe Cabin

Strong frame, safety glass on all directions, and safety net protect the operator and provide secure broad view in job site. Floating typed operators seat with air-bellows protects the operator from vibration and

provides very comfortable working conditions. Air condition, radio, and the heater are provided as basic specifications.

10) Sliding Suction Hood

With suction hood cab slid up and down by the operator in the cabin , the operator can perform drilling without others assistance correctly. The hood stuck to the ground prevents the debris from flying in drilling.

11) Auto Lubrication for Drifter

Without additional device, lubricating oil can be supplied from hydraulic tank directly. The automatic lubrication system removes the inconvenience of feeding oil frequently and protects the drifter from being damaged by lubrication oil shortage.

12) Centralized Electric Control System

All the electric control devices are centralized in the control box for checking any trouble easily.

13) Pre-Cleaner(Cyclone)-Optional Parts

Pre-cleaner installed between hood and dust collector protects the filters in the dust collector and the hose from being damaged by the debris.

14) Auto Grease Gun

Before the rod and the sleeve connected, greases the external screw by only pushing the button, which helps the rod and the sleeve charged tightly to get easily loosed.

15) Automatic Rod Changer

The operator connects or disconnects the rods by controlling only a few levers in the cabin without an assistant. This automatic rod exchange can be performed by means of sequential hydraulic schematic.

5 Rods(including the first rod) can be equipped in the cartridge of ARC

16) Cummins Engine with large output

Cummins engine with water cooling system supply sufficient power for travelling or operating at job site. Especially its world wide services network by Cummins will be a good point for the users.

17) Large Fuel Tank

Fuel tank can hold 250 liters and gives comparatively a long operating duration. The residual fuel can be observed in sight unless engine room opened.

18) Compressor On/Off Switch

Air compressor can be used only in case compressed air required by On/Off switch. The On/Off switch of compressor is effective to cut down the engine fuel consumption by unloading the compressor at the Off position.

5. Specifications

NO	ITEM			MODEL
				JD-800
1	Overall Dimensions	Gross weight	kg	10,550
		Overall length	mm	8,300
		Overall width	mm	2,470
		Overall height	mm	2,860
2	Crawler	Ground clearance	mm	540
		Oscillating angle		11
		Gradeability	°	30
		Traveling speed	km/h	3.8
3	Engine	Model		B5.9-C (CUMMINS)
		Rated output	ps/rpm	156 / 2,200
		Oscillating Angle	°	±11
4	Drifter	Model		JET-8
		Total Length	Mm	1,132
		Total Width	Mm	379
		Total Height	Mm	297
		Weight	Kgf	270
		Impact Frequency	Hz	40~50
		Rotational Torque	Kgf-m	Max. 88
		Rotational Frequency	RPM	Max. 190
		Impact Frequency	Bar	130~170
		Rotation Pressure	Bar	130
		Flusing Pressure	Bar	Max. 14
5	Air compressor	Model		CF75G(GHH-RAND)
		Working pressure	kg/cm ²	10.5
		Free air delivery	m ³	5
		Tank capacity	m ³	0.051
6	Guide	Overall length	mm	6,800(7,040)
		Slide length	mm	1,500
		Feed length	mm	3,740(4,300)
		Swing angle	R/L°	65 / 50
		Tilt angle	°	180

NO	ITEM			MODEL
				JD-800
7	Boom	Overall length	mm	2,100
		Lift angle	U/D。	50/30
		Swing angle	R/L。	45/15
8	Dust collector	Suction capacity	m ³ /min	24
		Number of filters	EA	4
		Blow pressure	mm/Aq	550
9	Rod changer	Weight	kg	300
		Number of rods		4+1
10	Bit & Rod	Bit dia		Φ 64~ Φ 102
		Bit design		CROSS,BUTTON
		Rod length	mm	3,060(3,660)
		Rod section		T38, T45
11	Hyd. sys.	Hyd. pump		Rexroth Variable Piston Pump
12	Auto rod changer	Type		○
		Number of Rod	EA	4 + 1

6. Specification Diagram

